

open 
SAFETY

open**SAFETY**

The open safety standard for all
industrial Ethernet solutions

What does Safety normally look like?

- Safety Relays within the cabinet
- Safety application by discrete wiring

- ➊ Additional DI/DO module
- ➋ Extra wiring of safe sensors
- ➌ Extra wiring required to control safe actuators
- ➍ Extra speed monitor for safe motion control functions
- ➎ Timer Relays for synchronous shutdown

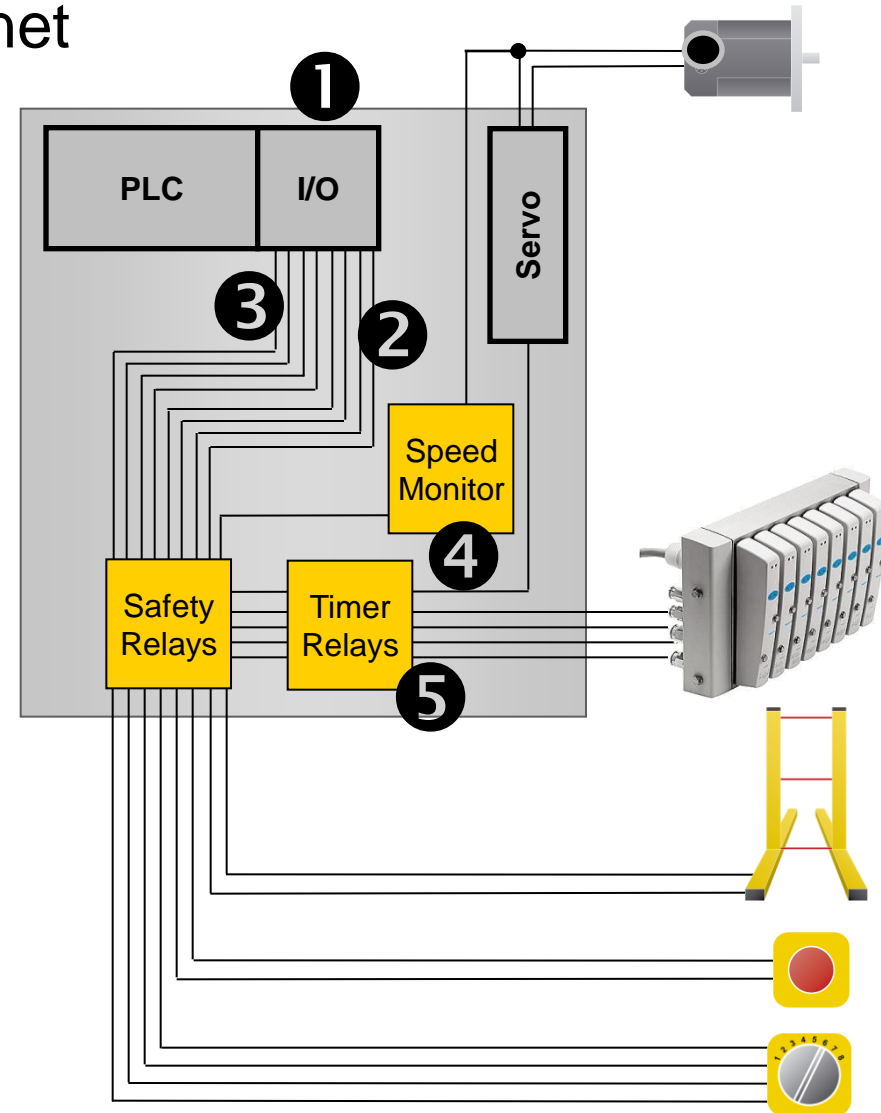

What Safety should look like?

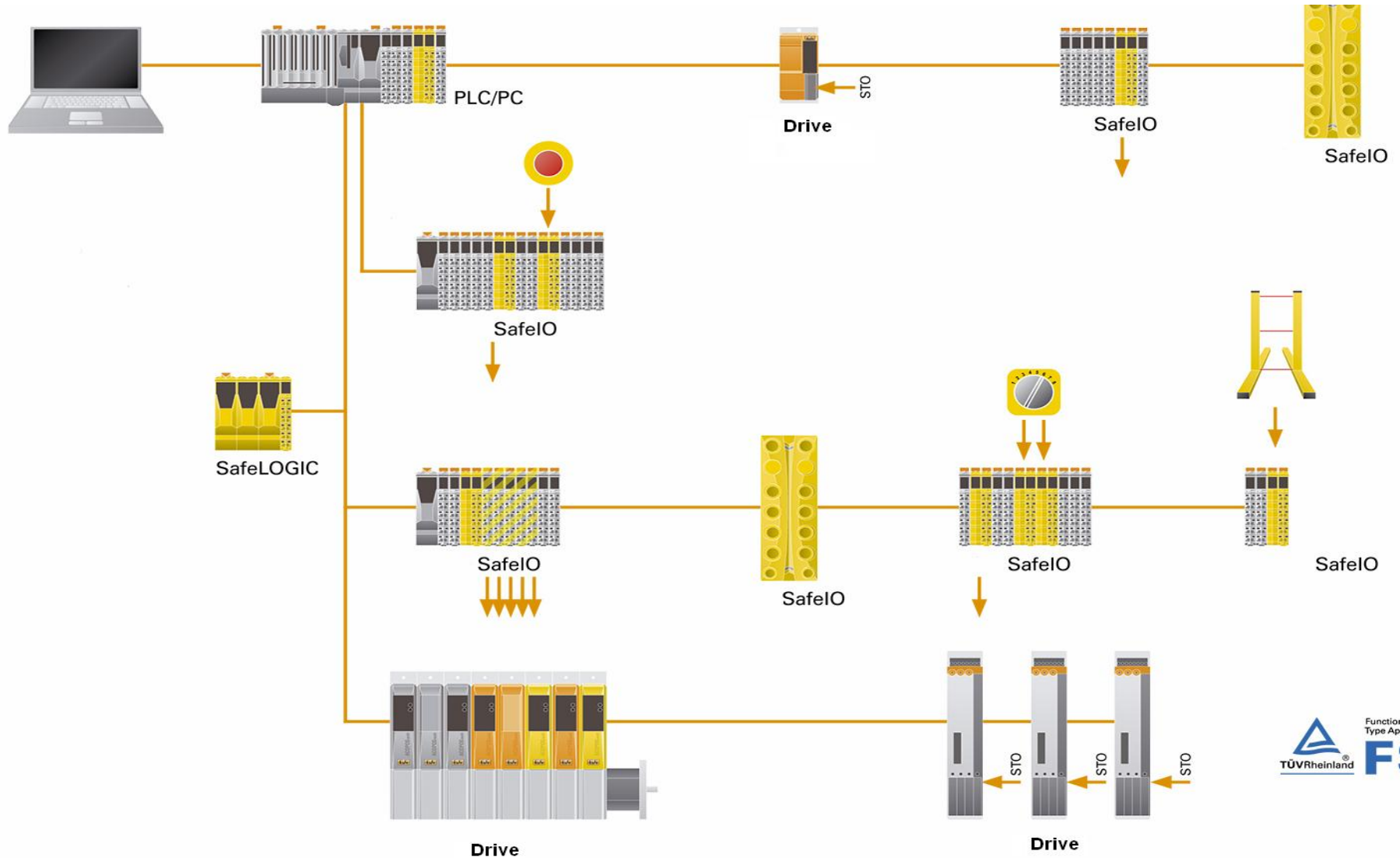

Benefit

1

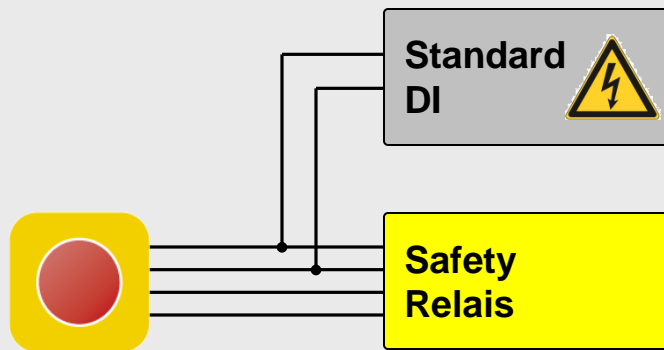

- **Additional Wiring**
- **Failure of standard I/O's can affect safety**

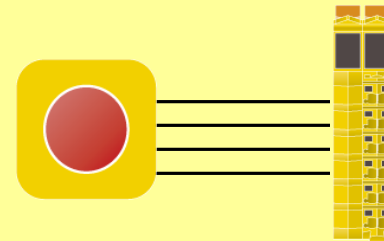

- **Less wiring**
- **Less components**

Decreased Response Time

Benefit

2

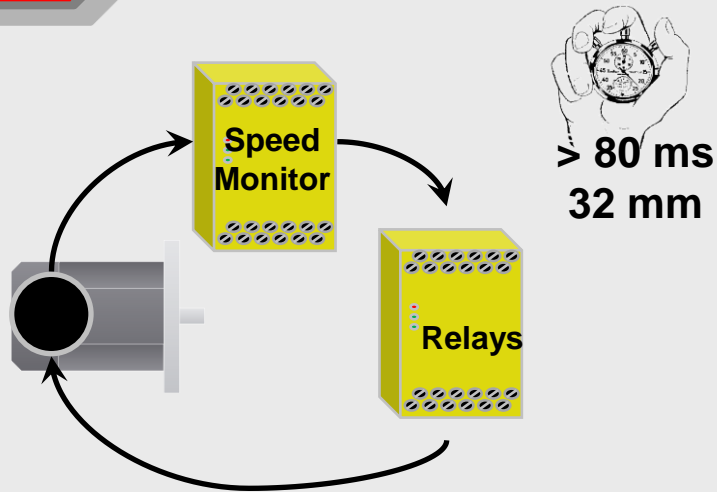

- Latency induced by relays

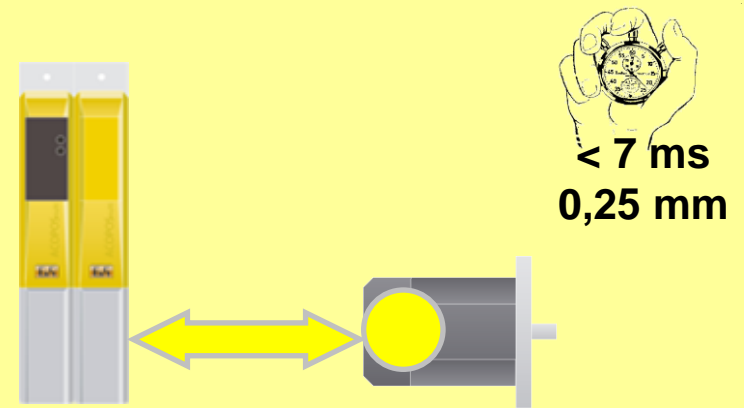

- Fastest response time
- Smaller footprint of machine

Elimination of Setup Errors

Benefit

3



- Significant risk of errors during maintenance

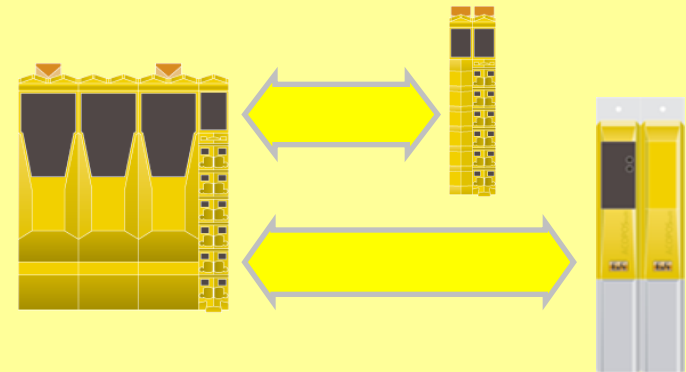

- Electronic data sheet
- Maintenance logging
- Password protection

Benefit

4

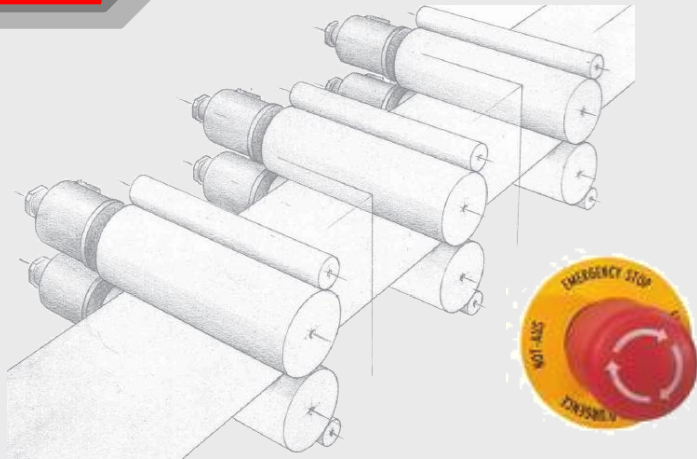

- Only Safe Torque Off

Function acc. IEC61800-5-2

STO – Safe Torque Off
STO1 – Safe Torque Off one channel
SBC – Safe Brake Control
SS1 – Safe Stop 1
SS2 – Safe Stop 2
SOS – Safe Operating Stop
SLS – Safely Limited Speed
SDI – Safe Direction
SLI – Safely Limited Increment
SMS – Safe Maximum Speed

- Intelligent safety functions

- Available Safety Protocols
 - ProfiSafe is **limited** to Profibus and Profinet
 - CIPSafety is **limited** to Rockwell protocols and SERCOS
 - Safety EtherCAT is **limited** to EtherCAT
 - Safety Net p is a **proprietary** protocol from PILZ
- These protocols are **proprietary** or **limited** to certain Fieldbus!
- These technologies are **NOT** compatible with each other!

- Available Safety Protocols
 - ProfiSafe is **limited** to Profibus and Profinet
 - CIPSafety is **limited** to Rockwell protocols and SERCOS
 - Safety EtherCAT is **limited** to EtherCAT
 - Safety Net p is a **proprietary** protocol from PILZ
 - openSAFETY is **opened** and available for **any fieldbus**
- openSAFETY is fully **opened** and totally **independent** of the fieldbus!

openSAFETY is open and independent

- Independence of underlying hardware, software and networking technologies
- Totally independent from technical and legal aspects

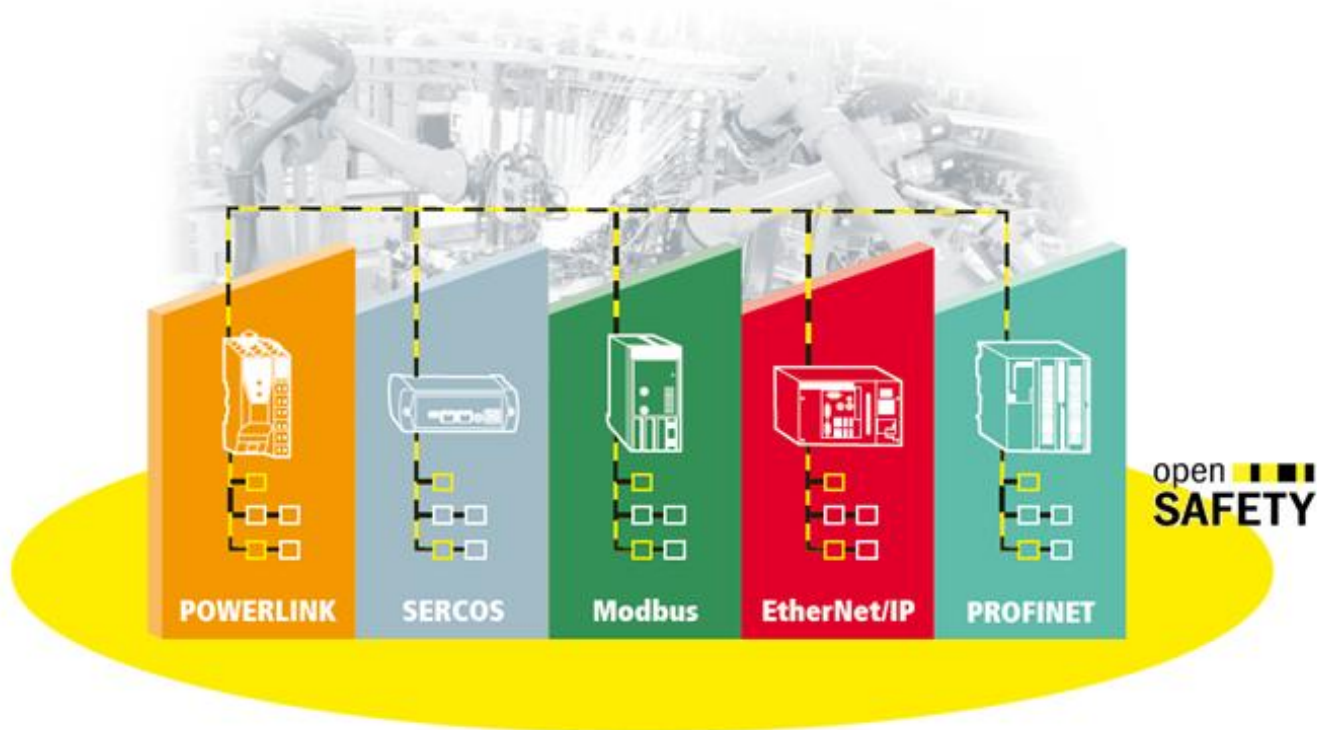

- openSAFETY is already operational on:
 - EtherNet/IP
 - Modbus TCP/IP
 - POWERLINK
 - SERCOS III
 - PROFINET
- openSAFETY covers 91% of Industrial Ethernet market !

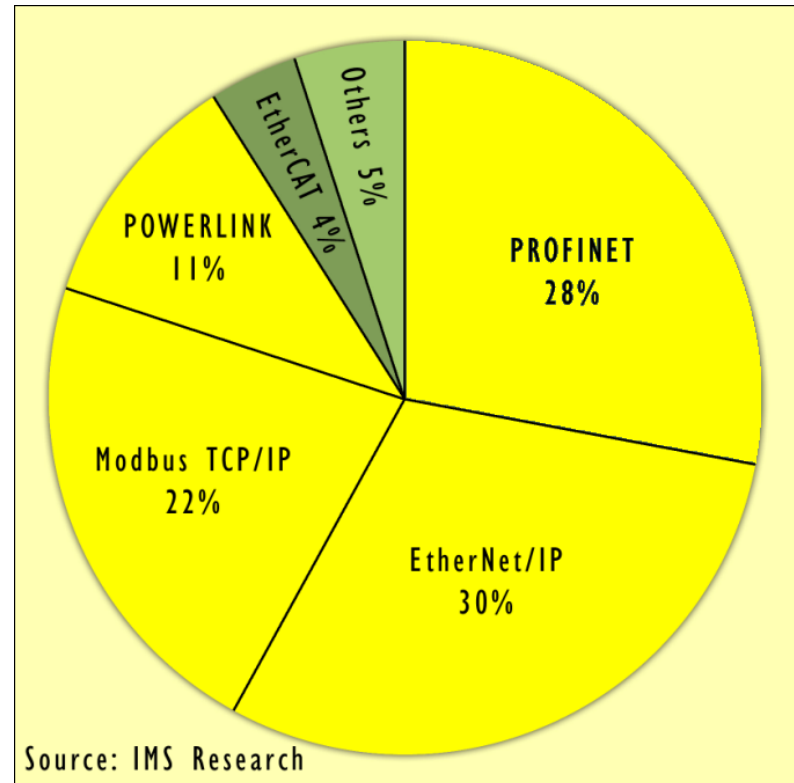

- One time development investment
 - same safety standard for all fieldbuses
- Reduced development time
 - Certified openSAFETY stack available
- Investment security
 - legal and technical independence
 - open source protocol stack
- Easy certification
 - TÜV certified conformance test
 - guaranteed interoperability



- One safety standard for your entire production plant
 - Cost reduction
 - Less down-time
 - Higher productivity
 - Easy maintenance



- Nestlé requests their providers to support openSAFETY



Bryan Griffen, Head of Electrical & Automation Engineering

openSAFETY supported by users



ALSTOM

NESTLE

SIDEL

"WE FEEL SAFE ABOUT IT"

- Reliability, availability, interoperability, fast reaction times, deterministic behavior and open architecture are all key factors for power generation control. POWERLINK communication technology fulfills these requirements for distributed control systems and machine control, and with openSAFETY we are guaranteed full data integrity when exchanging data over multiple networks.

openSAFETY is the only safety standard that is fully open and independent, thus ensuring safe data exchange and complete interoperability in a multi-vendor network environment.

openSAFETY is the ideal solution for critical automation processes, today and in the future!

Christian Korvenec
Vice President Technology,
Alstom Power Automation & Controls

ALSTOM

"WE FEEL SAFE ABOUT IT"

"Nestlé is using automation safety components from many different suppliers. Having a single safety communication standard will allow us to reliably exchange safety information across the entire factory floor, regardless of the brand of components. This standard would help facilitate engineering and commissioning, and reduce operations in regards to maintenance and troubleshooting of safety systems."



Christian Griffin
Senior Manager of Electrical & Automation Engineering
at Cooper and Engineering

The global standard for integrated safety technology significantly reduces wiring costs, enables faster commissioning and achieves top machine performance through efficient communication. openSAFETY gives you maximum productivity with certified safety. Compatibility to your industrial Ethernet solution guaranteed.

www.open-safety.org



"WE FEEL SAFE ABOUT IT"

"openSAFETY is a modern safety concept that allows Sidel to help our customers reduce the number of device types and the overall complexity of machine automation."

Stefano Pasquali
Commercial Part Technical Manager
SIDEL



The global standard for integrated safety technology significantly reduces wiring costs, enables faster commissioning and achieves top machine performance through efficient communication. openSAFETY gives you maximum productivity with certified safety. Compatibility to your industrial Ethernet solution guaranteed.

www.open-safety.org



The global standard for integrated safety technology significantly reduces wiring costs, enables faster commissioning and achieves top machine performance through efficient communication. openSAFETY gives you maximum productivity with certified safety. Compatibility to your industrial Ethernet solution guaranteed.

www.open-safety.org



openSAFETY for all industries

