

OMRON

Modbus Solution CP1H / CP1L / CJ1 / CJ2 / CS1

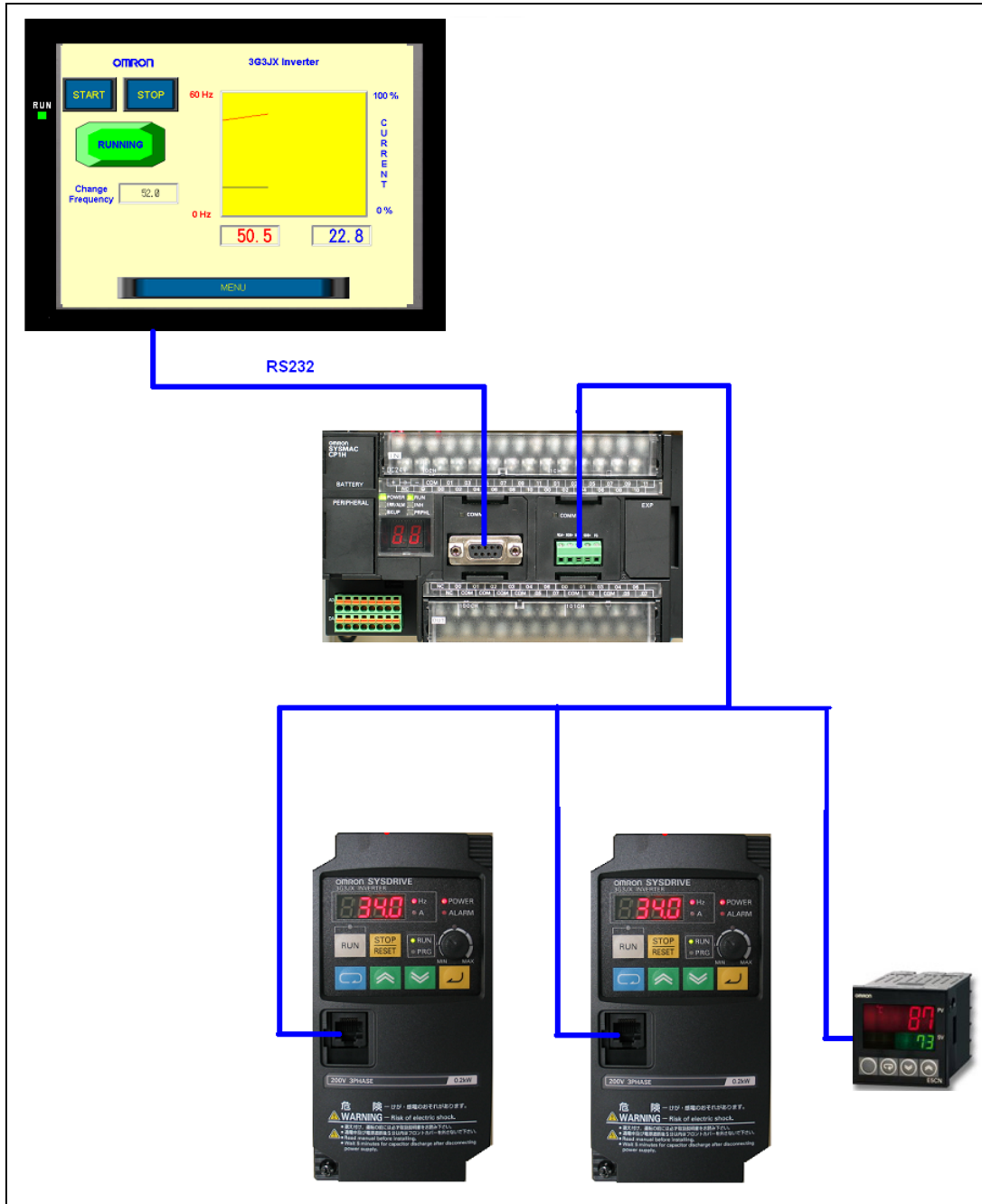

Section 1. Overview

The Omron CP1H and CP1L PLCs offer a built in function called 'Easy Modbus', that performs a Modbus RTU Master function, allowing the PLC to communicate with devices that use the Modbus RTU protocol, such as inverters, scales, temperature controllers, etc. The CJ1 / CJ2 / CS1 PLCs support Modbus through a Protocol Macro. While the 'Easy Modbus' or 'Protocol Macro' functions are powerful functions, they require the user to develop a ladder program to feed data to and retrieve data from the 'Easy Modbus' or 'Protocol Macro' function. This can be intimidating to a user. This Modbus *Solution* was developed to provide a pre-written solution to Modbus RTU applications, supporting up to 100 'items' to read and 100 'items' to write. An 'item' is an individual data point on a device such as 'present temperature of node 4', or 'frequency reference on node 7'.

The Modbus RTU function codes that are supported are:

- 01: Read Coil Status
- 02: Read Input Status
- 03: Read Holding Registers (1 or 2 registers)
- 04: Read Input Registers (1 – 32 coils)
- 05: Force Single Coil
- 06: Preset Single Register
- 0F: Force Multiple Coils (1 – 32 coils)
- 10: Preset Multiple Registers (1 or 2 registers)

The NS series HMI application that is provided is not necessary for the solution, but is intended to assist in setup and monitoring of the Modbus Solution.

Memory Considerations:

The Modbus Solution uses ~ 1,500 steps of PLC User Memory for CP1H / CP1L and ~1600 steps for CJ1 / CJ2 / CS1.

This represents the following amount for each PLC CPU type. Keep this memory usage in mind when selecting a PLC CPU for an application.

PLC	Total UM	Remaining	% Used
CP1H-X, XA, Y/ CJ1M-CPU13	21,504 Steps	~ 20,000 steps	7%
CP1L-M / CJ1M-CPU12	11,264 Steps	~ 9,700 Steps	14%
CP1L-L / CJ1M-CPU11	6,144 Steps	~ 4,600 Steps	25%
CS1G-CPU42-H / CJ1G-CPU42-H	11,264 Steps	~ 9,700 Steps	14%
CS1G-CPU43-H / CJ1G-CPU43-H	21,504 Steps	~ 20,000 steps	7%
CS1G-CPU44-H / CJ1G-CPU44-H	31,744 Steps	~ 30,000 steps	5%
Others – Negligible Memory Usage			

Section 2. Hardware Requirements

PLC To use the Modbus Solution

- 1 CP1H or CP1L PLC
- 1 CP1W-CIF11 or CIF12 RS422/485 serial adapter
or
- 1 CJ1 / CJ2 / CS1 with Serial Communications Unit (SCU41 or SCU31)

To use the NS Series HMI application

- The PLC must have an RS232 port (CP1H or CP1L-M type, or CJ1 / CJ2/ CS1)
- 1 CP1W-CIF01 for communications to the HMI from CP1H or CP1L
- 1 NS8 HMI
- 1 C200H-CN510-EU (or similar) PLC to NS cable

Section 3. Setup for CP1L / CP1H

The CP1W-CIF11 must be installed in the rightmost option board position. For CPUs with 2 option board positions, do not use the leftmost position. The ladder program was not written for this option board position.

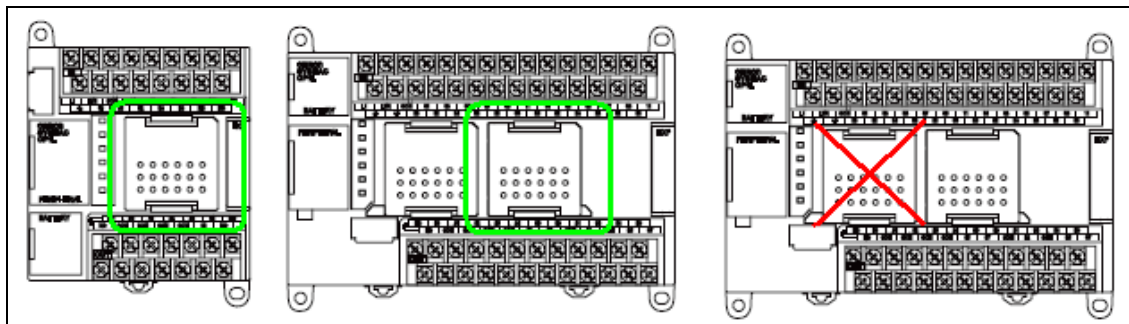

For RS-485 communications, set the DIP switches on the back of the CP1W-CIF11 or CIF12 adapter as shown prior to installing in the PLC.

(Rear panel)

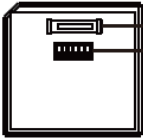

CPU unit connector
Operation setup
DIP switches

No.	Setting	ON/OFF	Content
1	Presence of terminating resistance	ON	Terminating resistance present
2	2/4-wire selection	ON	2-wire type
3	2/4-wire selection	ON	2-wire type
4	-	OFF	Always OFF
5	RS control for RD	ON	Enabled
6	SD control for RD	ON	Enabled

The Port that is being used for Modbus communications will need to be configured as shown. Be certain to download the PLC settings to configure the serial port, and make certain that the DIP Switch associated with the port is OFF. This is DIP Switch 4 on CP1L-L, and DIP Switch 5 on CP1L-M and CP1H.

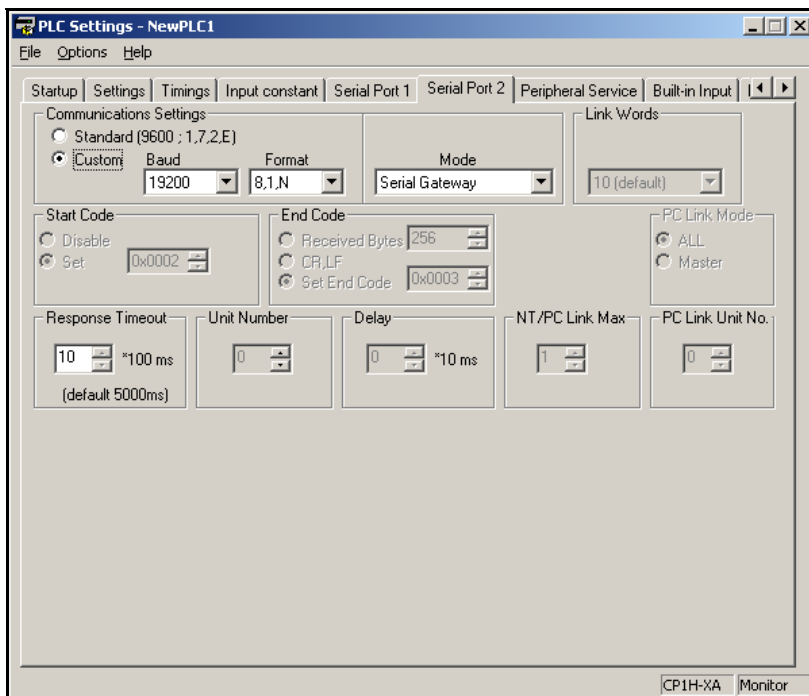

PLC Settings - NewPLC1

File Options Help

Startup Settings Timings Input constant Serial Port 1 Serial Port 2 Peripheral Service Built-in Input

Communications Settings

Standard (9600; 1,7,2,E)
Custom

Baud: 19200 Format: 8.1.N Mode: Serial Gateway Link Words: 10 (default)

Start Code: Disable Set: 0x0002

End Code: Received Bytes: 256 CR,LF Set End Code: 0x0003

PC Link Mode: ALL Master

Response Timeout: 10 *100 ms (default 5000ms) Unit Number: 0 Delay: 0 *10 ms NT/PC Link Max: 1 PC Link Unit No.: 0

CP1H-XA Monitor

Section 3. Setup for CJ1 / CJ2 / CS1

The CJ1 / CJ2 / CS1 configuration for the Modbus Solution requires an SCU31 / SCU41 module.

The built in ports on the PLC CPU cannot be used for this function. An SCB (Serial Communications Board) on a CS1 cannot be used for this function.

The SCU module must be set for unit #F, and the top communications port is used as shown. Set the 2/4 wire mode for 2 wire (RS485), and the Terminating Resistance switch to ON.

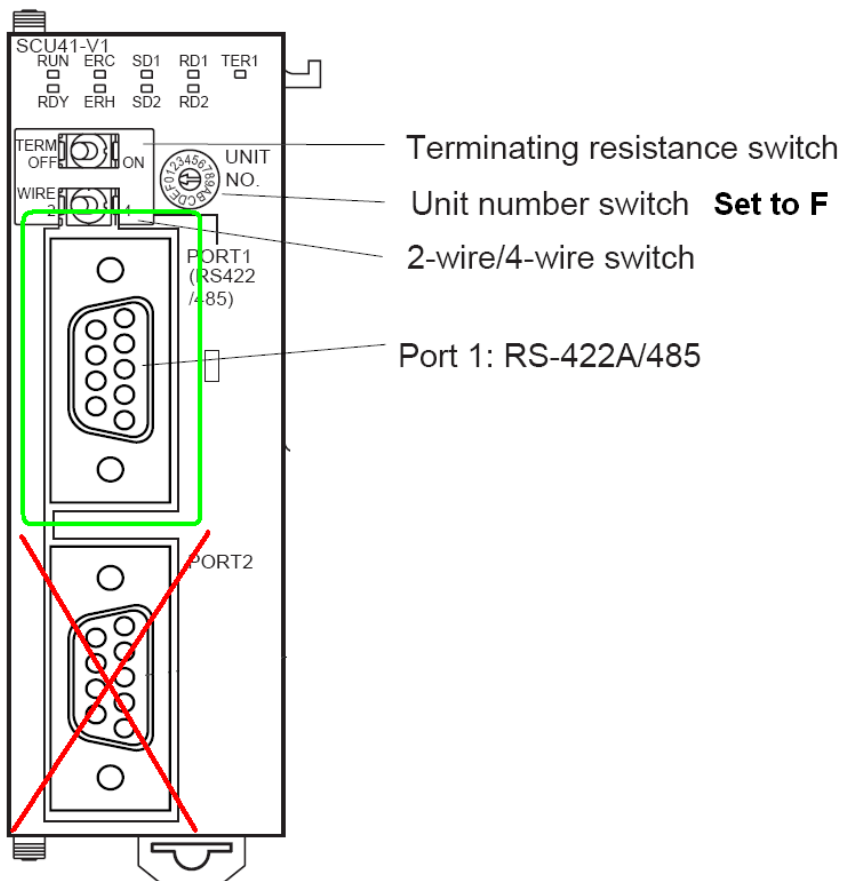

The port must be configured through the I/O table of CX Programmer, and setup as shown below.

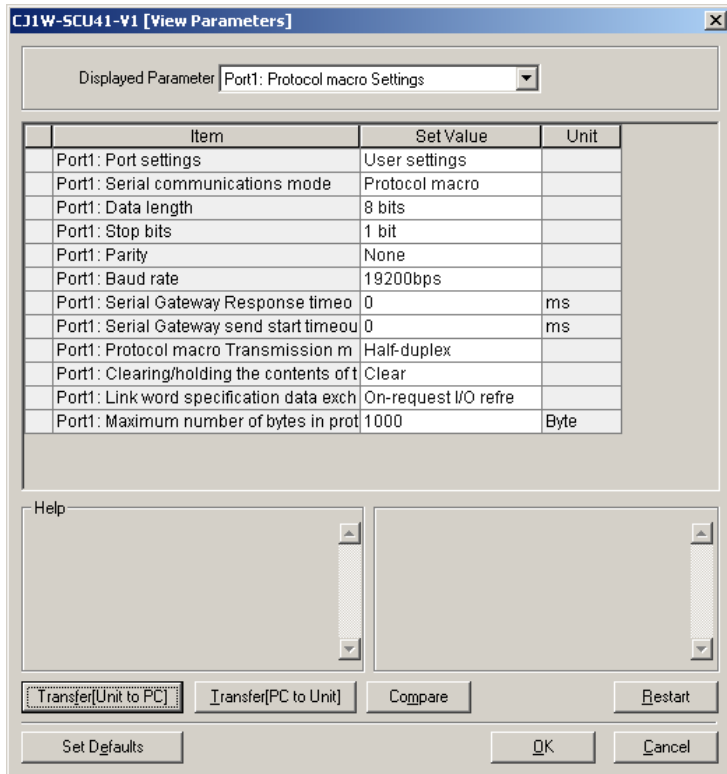

The Protocol Macro must also be downloaded to the SCU module via CX Protocol.

Section 4. Data Layout for Modbus RTU data exchange

To read and write data from and to a Modbus RTU capable device, the user simply manipulates data in data tables in the PLCs DM (Data Memory) area. The Modbus Solution automatically communicates to the Modbus devices based on the data tables.

To read from a Modbus Slave device: The user fills in the 'Read Data' Table as follows. Item 1 is shown, but the data layout is the same for all items. Shaded items are set by the user, non-shaded items are populated by the Modbus Solution.

Item 1: D5000 – D5009

Item 2: D5010 – D5019

...

Item 100 : D5990 – D5999

The PLC program will cycle through the items in order. To mark the last item to read, enter 'F000' in the 'Last Item to Read' memory location for the last 'item'. Set '0000' for all but the last 'item'. If there are no read items for the application, set D5009 to 'E000'.

Address	Setting	
D5000	Modbus Slave Node Number	In HEX
D5001	Modbus Function Code	In HEX
D5002	Starting Modbus Address to Read	In HEX
D5003	Number of Modbus Addresses to Read	In HEX, 0 – 31 for coils, 0 or 1 for registers
D5004	First word of Response Data	
D5005	Second word of Response Data	Not used if < 16 coils or 1 register is read
D5006	Not used	
D5007	Not used	
D5008	Is the Data Valid?	FFFF = invalid (ie error), 0000 = valid, F000 = data not yet read (set on powerup)
D5009	Last Item to Read?	Set to F000 if this is the last item to read

Example: To read the present frequency and current for an Omron 3G3JX inverter, the Read Data Tables would be configured as follows:

Address	Value	Notes	Address	Value	Notes
D5000	0001	Node 1	D5010	0001	Node 1
D5001	0003	Function code 3	D5011	0003	Function code 3
D5002	1001	'Frequency' Register	D5012	1002	'Current' Register
D5003	0001	Read 1 Register	D5013	0001	Read 1 Register
D5004	0000	Freq. Returned Here	D5014	0000	Current Returned Here
D5005	0000		D5015	0000	
D5006	0000	Not Used	D5016	0000	Not Used
D5007	0000	Not Used	D5017	0000	Not Used
D5008	0000	Data is valid	D5018	0000	Data is valid
D5009	0000	Not last item	D5019	F000	Last Item

To write to a Modbus Slave device: The user fills in the 'Write Data' Table as follows. Item 1 is shown, but the data layout is the same for all items. Shaded items are set by the user, non-shaded items are populated by the Modbus Solution.

Item 1: D6000 – D6009
 Item 2: D6010 – D6019
 ...
 Item 100 : D6990 – D6999

The PLC program will cycle through the items in the read table, and write data to a Modbus Slave only on **Data Change**. To mark the last item to write, enter 'F00x' in the 'Last Item to Write' memory location for the last 'item'. Set '000x' for all but the last 'item'.

To set a particular write 'item' to FFFF **after the data is written to the device**, set xxxA in the 'Last Item' field. This allows the same value to be written over and over again in the Data register of the Modbus Solution, and the Modbus Solution will correctly detect the **changing** data.

0000 = Not Last Write Item, do not detect same value write
 000A = Not Last Write Item, detect same value write
 F000 = Last Write Item, do not detect same value write
 F00A = Last Write Item, detect same value write.

Address	Setting	
D6000	Modbus Slave Node Number	In HEX
D6001	Modbus Function Code	In HEX
D6002	Starting Modbus Address to Write	In HEX
D6003	Number of Modbus Addresses to Write	In HEX, 0 – 31 for coils, 0 or 1 for registers
D6004	First word of Write Data	
D6005	Second word of Write Data	Not used if < 16 coils or 1 register is read
D6006	Copy of last data sent first write word	Used to detect 'changed' data
D6007	Copy of last data sent second write word	Used to detect 'changed' data
D6008	Last Write Successful?	FFFF = unsuccessful (ie error), 0000 = valid, F000 = data not yet written (set on powerup)
D6009	Last Item to Write / Detect Same Data?	0000, 000A, F000, F00A as explained above

Example: To Write a Frequency Reference for Omron 3G3JX inverters at nodes 9 and 12, the Write Data Tables would be configured as follows:

Address	Value	Notes	Address	Value	Notes
D6000	0009	Node 9	D6010	000C	Node 12
D6001	0010	Function code 10	D6011	0010	Function code 10
D6002	0001	'F Ref' Register	D6012	0001	'F Ref' Register
D6003	0001	Write 1 Register	D6013	0001	Write 1 Register
D6004	0096	96 = 15.0 hz	D6014	017C	17C = 38.0 hz
D6005	0000	Not used	D6015	0000	Not used
D6006	0000	Program controlled	D6016	0000	Program controlled
D6007	0000	Program controlled	D6017	0000	Program controlled
D6008	0000	Last Write Successful?	D6018	0000	Last Write Successful?
D6009	000A	Not last item, detect same write value	D6019	F00A	Last Item, detect same write value

Section 5. Used Memory Areas

The following memory areas are used for the Modbus Solution, and cannot be used for other purposes in the PLC:

Timers 13, 14, 15

W0 – W249

D5000 – D6999

Jump / Jump End DF, EF, FF

Section 6. Error Logging and Cycle Time Monitoring

The Modbus Solution has build in error detection. Each read 'item' and write 'item' has its own status area. For 'read' items, this is the 'Is the Data Valid' field. For 'write' items, this is the 'Last Write Successful' field.

Each Read / Write has a 3 retry on timeout setting. The timeout value is set in the PLC port setup for CP1H / CP1L, and in the Protocol macro for CJ1 / CJ2 / CS1.

The Modbus Solution has an overall error log. The last 5 errors are logged as follows: (W220 + W221 is the most recent error). Consult the Modbus specification for the slave device to determine the cause and solution to the Modbus error.

Address	Item	Example
W220	Record 1 Node Number Function Code	0205 (node 2, function 05)
W221	Record 1 DM Area that caused error	1392 (5010 DEC) = D5010
W222	Record 2 Node Number Function Code	0710 (node 7, function 10)
W223	Record 2 DM Area that caused error	17A2 (6050 DEC) = D6050
W224	Record 3 Node Number Function Code	0801 (node 8, function 01)
W225	Record 3 DM Area that caused error	13CE (5070 DEC) = D5070
W226	Record 4 Node Number Function Code	0A03 (node 10, function 03)
W227	Record 4 DM Area that caused error	157C (5500 DEC) = D5500
W228	Record 5 Node Number Function Code	0710 (node 4, function 10)
W229	Record 5 DM Area that caused error	1838 (6200 DEC) = D6200

There is also a complete copy of the Modbus string sent out the port, and received back in the port for the last Modbus error. This is for CP1H / CP1L Only. For CJ1 / CJ2 / CS1, use the Data Trace function in CX Protocol to analyze the Modbus strings.
W230 – W239 = Last sent Modbus Command that caused an error.
W240 – W249 = Last received Modbus command that contained an error.

The current polling cycle time can be viewed in W216 as xx.xx seconds as a BCD data type. Example: W216 = 0140 means it takes 1.40 seconds to scan all the 'items' in the read tables.

The CP1H / CP1L PLCs scan 10 'items' in ~ 0.40 seconds (at 19,200 bps).

The CJ1 / CJ2 / CS1 PLCs scan 10 'items' in ~ 1.30 seconds (at 19,200 bps).

The difference in these times is due to the overhead associated with Protocol Macros.

Function 10 (Preset Multiple Holding Registers)

D6000	Modbus Node Number (HEX)				
D6001	Modbus Function Code (HEX)				
D6002	Starting Modbus Register (HEX)				
D6003	Number of Registers to Write (HEX)	01 or 02	1 Register	2 Registers	1 8 Digit Register
D6004	First word of data to write		Data	1st register	2 Highest Bytes
D6005	Second word of data to write		0000	2nd register	2 Lowest Bytes
D6006	Last Scan copy of First Word of data to write				
D6007	Last Scan copy of Second Word of data to write				
D6008	Data Written Correctly???	FFFF = invalid, 0000 = valid, set to F000 on PLC startup			
D6009	End of list?	F00x = End of List x00A = Auto Clearing of data after Writing			

Note: For function code 10, when writing a single 2 register parameter (such as Accel in a 3G3JX), the data needs to be presented in a word swapped format.

Section 8. Table Setup Example for 3G3JX Inverter

Read Item 1 = Read All Status Coils from node 1

Read Item 2 = Read Frequency and Current from Node 1

Address	Value	Notes	Address	Value	Notes
D5000	0001	Node 1	D5010	0001	Node 1
D5001	0001	Function code 1	D5011	0003	Function code 3
D5002	0000	Start at Coil 0	D5012	1001	'Frequency' Register
D5003	0019	Read 25 Coils (19 HEX)	D5013	0002	Read 2 Registers
D5004	0000	Coil status	D5014	0000	Frequency Returned Here
D5005	0000	Coil status	D5015	0000	Current Returned Here
D5006	0000	Not Used	D5016	0000	Not Used
D5007	0000	Not Used	D5017	0000	Not Used
D5008	0000	Data is valid	D5018	0000	Data is valid
D5009	0000	Not last item	D5019	F000	Last Item

Write Item 1 = Control Run / Stop and FWD / REV to Node 1

Write Item 2 = Write Frequency to Node 1

Write Item 3 = Reset Inverter Alarm to Node 1

Address	Value	Notes	Address	Value	Notes
D6000	0001	Node 1	D6010	0001	Node 1
D6001	000F	Function code F	D6011	0010	Function code 10
D6002	0000	Start Coil 0	D6012	0001	'F Ref' Register
D6003	0002	Write 2 Coils	D6013	0001	Write 1 Register
D6004	xx00	0100 :Run, 0000 :Stop	D6014	xxxx	Frequency
D6005	0000	Not used	D6015	0000	Not used
D6006	0000	Program controlled	D6016	0000	Program controlled
D6007	0000	Program controlled	D6017	0000	Program controlled
D6008	0000	Last Write Successful?	D6018	0000	Last Write Successful?
D6009	000A	Not last item, detect same write value	D6019	000A	Not last item, detect same write value

Address	Value	Notes
D6020	0001	Node 1
D6021	0005	Function code 5
D6022	0003	Reset Alarm Coil
D6023	0001	Write 1 Coil
D6024	xx00	FF00 :Reset
D6025	0000	Not used
D6026	0000	Program controlled
D6027	0000	Program controlled
D6028	0000	Last Write Successful?
D6029	F00A	Last Item, detect same write value

Appendix A: 3G3JX Inverter Setup (provided as reference material)

1. Connect the PLC to the inverter as shown

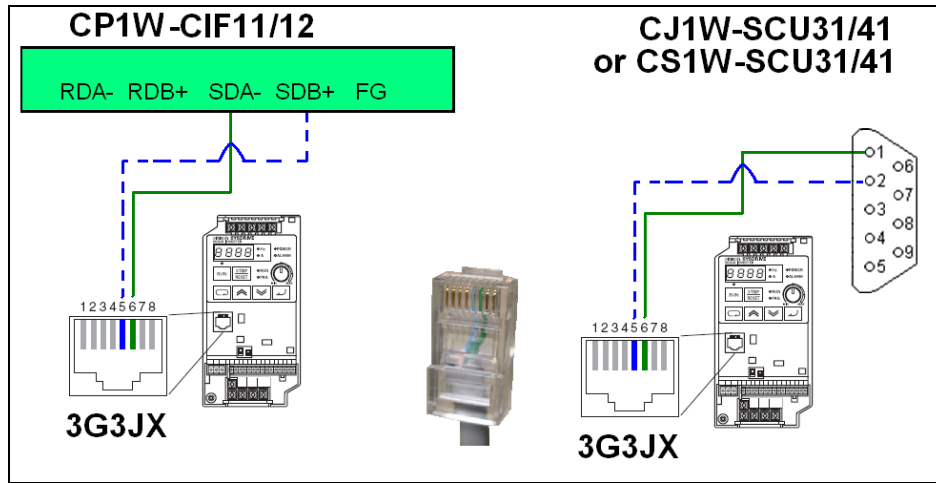

2. Initialize the Inverter (to erase any previous settings) as follows:
 - a. Unplug the inverter.
 - b. Verify that S7 is set for OPE. Leave S8 in the Off position.

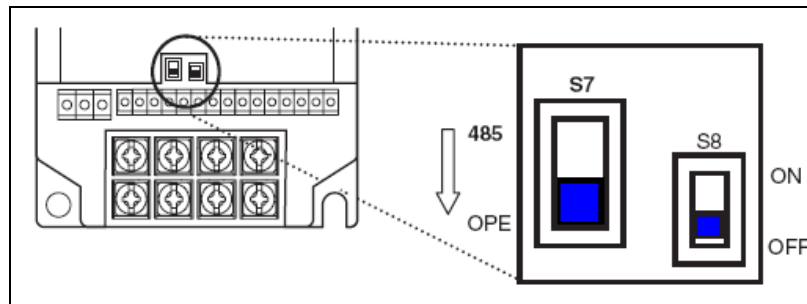

- c. Plug in the inverter and wait ~ 30 seconds in case the inverter is set to use Modbus for communications. This lets it timeout.
- d. Set B84 to 01.
- e. Press and hold the **Mode** and **Decrement** Keys simultaneously.
- f. Press and Hold the **Stop/Reset** key until the display blinks.
- g. Release all 3 keys and let the inverter go through its initialization.

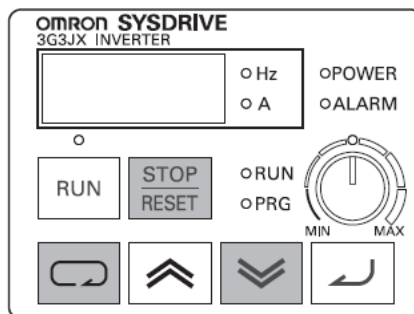

3. Change the following Inverter Parameters using the Operator Keypad.
 - a. A001 = 03. Set Modbus as Frequency Reference Input
 - b. A002 = 03. Set Modbus as the Run/ Stop command reference
 - c. C070 = 03. Set Modbus as the input method (not keypad).
 - d. C071 = 06. Set 19,200 as the baud rate
4. Unplug the inverter after making these changes.
5. Set DIP S7 to 485. Leave S8 in the Off position.

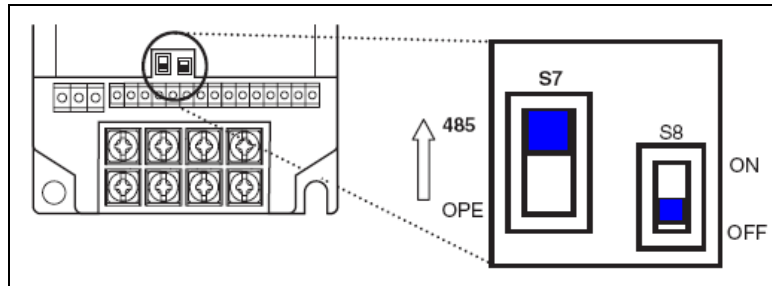

6. Plug in the inverter.

Appendix B: 3G3JX Coil Numbers

When starting at Coil 1 (set in the read item as '0' by Modbus) for a read or write, the coil numbers are as follows for a 3G3JX. This example uses Read Item 1 (D5000) as the item for reading the coils.

Shaded = Read only

5004.00	Coil 9	Multi-Function Input 3
5004.01	Coil 10	Multi-Function Input 4
5004.02	Coil 11	Multi-Function Input 5
5004.03	Coil 12	Not Used
5004.04	Coil 13	Not Used
5004.05	Coil 14	Operation Status
5004.06	Coil 15	Rotation Direction
5004.07	Coil 16	Inverter Ready
5004.08	Coil 1	Run Commands
5004.09	Coil 2	Rotation Direction Command
5004.10	Coil 3	External Trip (EXT)
5004.11	Coil 4	Trip Reset (RS)
5004.12	Coil 5	Not Used
5004.13	Coil 6	Not Used
5004.14	Coil 7	Multi-Function Input 1
5004.15	Coil 8	Multi-Function Input 2
5005.00	Coil 25	Signal During Run
5005.01	Coil 26	Not Used
5005.02	Coil 27	Data Writing
5005.03	Coil 28	CRC Error
5005.04	Coil 29	Overrun Error
5005.05	Coil 30	Framing Error
5005.06	Coil 31	Parity Error
5005.07	Coil 32	Checksum Error
5005.08	Coil 17	Not Used
5005.09	Coil 18	Not Used
5005.10	Coil 19	Not Used
5005.11	Coil 20	Alarm Signal
5005.12	Coil 21	Excessive PID Deviation Signal
5005.13	Coil 22	Overload Warning
5005.14	Coil 23	Frequency Arrival Signal (Over Set Frequency)
5005.15	Coil 24	Frequency Arrival Signal (Constant Speed)

Revision History

Date	Notes	Version
6/8/2009	Original Document	1.50
6/11/2009	Added CJ1/CS1/CJ2 Added Memory Layout for Functions Corrected Error in 3G3JX Memory Example	2.00
6/18/2009	Changed PMCR timeout to 300 ms from 1 sec Added 'No Read Items' option	2.05